

Level-1 Controlled Substances are banned

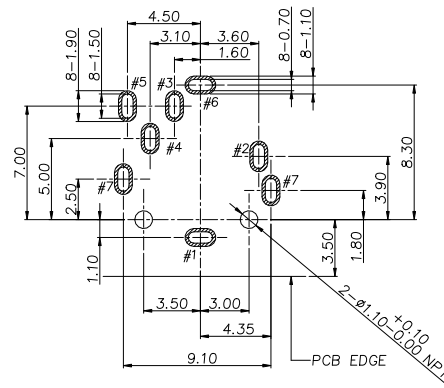

RECOMMENDED P.C.B LAYOUT TOP VIEW (TOLRANCE:±0.05)

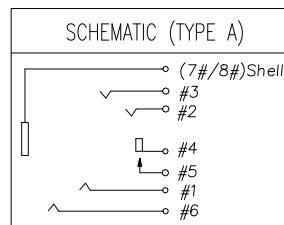
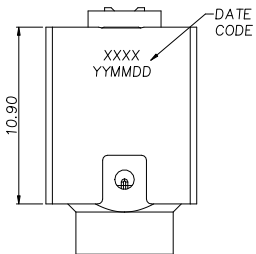
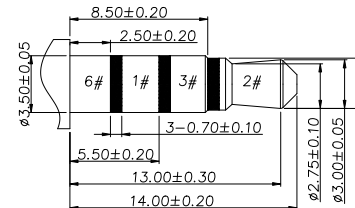
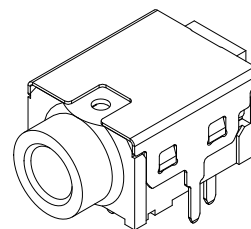
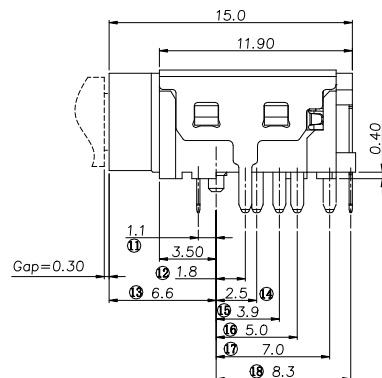
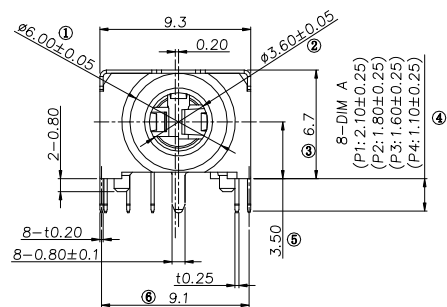

MATE PLUG (4 POLE)

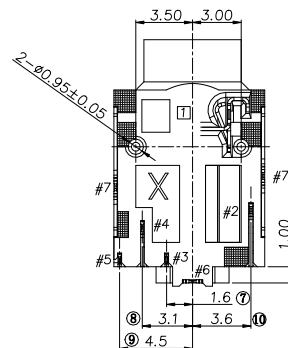

SPECIFICATION**

1. Electrical characteristics
 - 1-1. Voltage rating: DC 30V.
 - 1-2. Current rating: 0.5A
 - 1-3. Contact resistance: 30mΩ Max. (Initial)
After test: 50mΩ Max.
 - 1-4. Insulation resistance: 100MΩ Min (500V DC).
 - 1-5. Withstanding voltage: 500V AC.
2. Mechanical characteristics
 - 2-1. Life test: 5000 cycles
 - 2-2. Mating force: 3-30N
Unmating force: 3-30N
3. Salt Spray: **Matte Tin Area 8 hours, Gold nickel Area 24 hours,**
4. Wave Solder 265°C, 3-5 sec.
IR Reflow, Peak Temp 230-250°C, 20-90 sec.
5. Mark "⊗" is Key Control Size.

9	Housing	1	PA10T	—	Black, UL 94V-0
8	Shell	1	SUS304	—	Nickel 50u* Plating All Over
7	CONTACT 5	1	BRONZE	—	Gold Flash Plating At Contact Area; Matte-TIN Plating At Solder Tail Area; Nickel 50u* Under Plating All Over
6	CONTACT 4	1	BRONZE	—	Gold Flash Plating At Contact Area and Solder Tail Area; Nickel 50u* Under Plating All Over
5	CONTACT 4	1	BRONZE	—	Gold Flash Plating At Contact Area and Solder Tail Area; Nickel 50u* Under Plating All Over
4	CONTACT 6	1	BRONZE	—	Gold (Gold Flash OR Gold 30u*) Plating At Contact Area; Matte-TIN Plating At Solder Tail Area;
3	CONTACT 3	1	BRONZE	—	Matte-TIN Plating At Solder Tail Area;
2	CONTACT 2	1	BRONZE	—	Nickel 50u* Under Plating All Over
1	CONTACT 1	1	BRONZE	—	Nickel 50u* Under Plating All Over
NO.	DESCRIPTION	QTY	MATERIAL	COLOR	REMARK

GENERAL TOLERANCE UNLESS OTHERWISE SPECIFIED



General	Angle
X ± 0.50	X ° ± 3°
X.X ± 0.30	X.X ° ± 2°
X.XX ± 0.20	X.XX ° ± 1°
X.XXX ± 0.10	

CUSTOMER COPY	TITLE: PHONE JACK
PART NO.	PJ-D3047A

PROJ:	SCALE: 1:1	UNIT: mm	SIZE: A4	SHEET: 1 OF 1
-------	------------	----------	----------	---------------

DESIGN	Steven	12'/06/07			
CHECK	Jason	12'/06/07			
APPRO.	Max.hu	12'/06/07			
ECN (DCN) NO.	REV	DATE	DESCRIPTION	CHANGE	APPRO.
	0	12'/06/07	NEW	Steven	Max.hu