

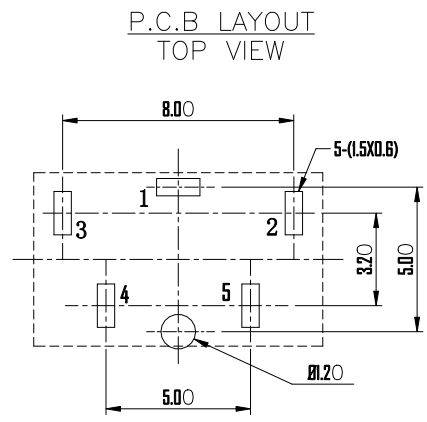

Level-1 Controlled Substances are banned

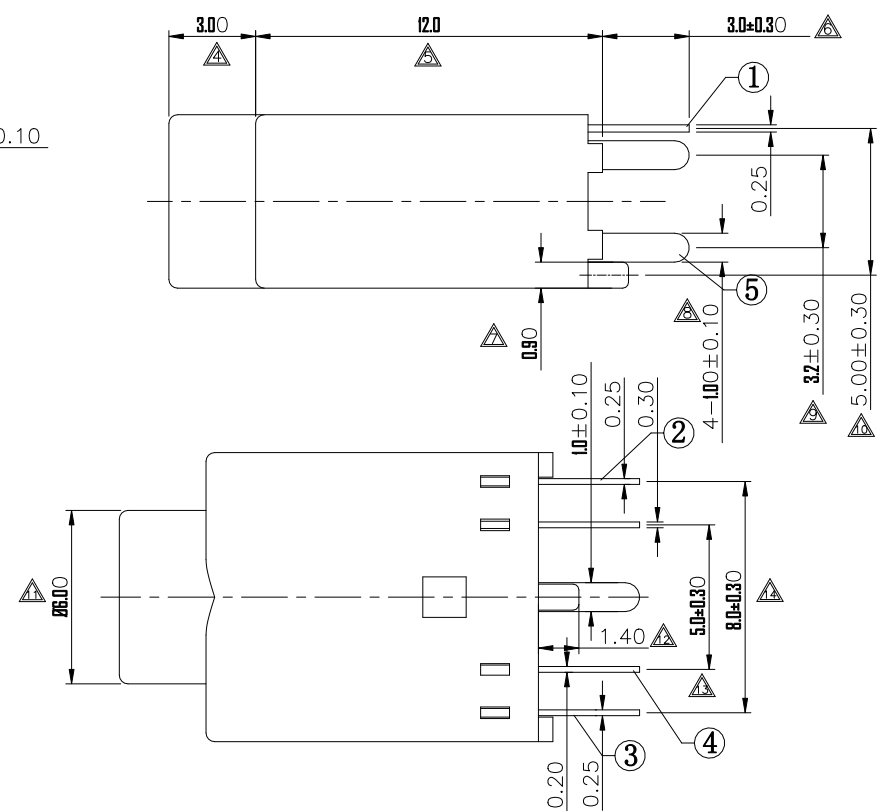
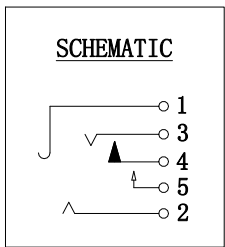
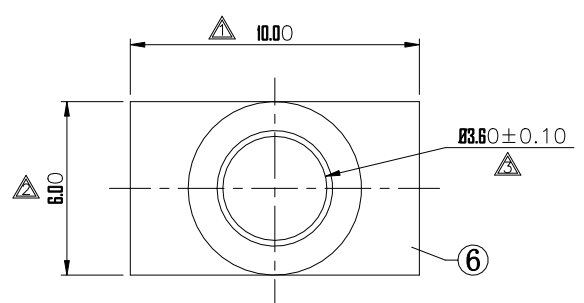

**SPECIFICATION**  
 1.Rating : DC 30V 0.5A;  
 2.Contact resistance: ≤0.03Ω;  
 3.Insulation resistance: ≥100MΩ (DC250V);  
 4.Withstand voltage: 500VAC ;  
 5.Insertion and extraction force: 3-30N;  
 6.life test: 5,000 cycles.  
 7.Marked ▲ are important dimensions.

NO.	DESCRIPTION	QTY	MATERIAL	COLOR	REMARK
6	HOUSING	1	PBT	—	—
5	FLAT PIECE	1	BRASS	—	Ag-Plating
4	SPRING PIECE	1	SUS301	—	Ag-Plating
3	SPRING PIECE	1	BRONZE	—	Ag-Plating
2	SPRING PIECE	1	BRONZE	—	Ag-Plating
1	CONTACT FOOT	1	BRONZE	—	Ag-Plating

GENERAL TOLERANCE UNLESS OTHERWISE SPECIFIED		盛聰电子有限公司 SHENG CONG ELECTRONIC CO.,LTD	
General	Angle		
X ± 0.50	X ° ± 3°	CUSTOMER COPY	TITLE: PHONE JACK
X.X ± 0.30	X.X ° ± 2°		
X.XX ± 0.20	X.XX ° ± 1°	PART NO.	PJ-03058H
X.XXX ± 0.10			
PROJ:	SCALE: 3:1	UNIT:mm	REV: A4 SHEET: 1 OF 1

ECN(OCN) NO.	REV	DATE	DESCRIPTION	CHANGE	APPRO.	DESIGN	DATE
	0	12'/06/13	NEW		Steven	Max.hu	12'/06/13
					Jason	Max.hu	12'/06/13
					Max.hu	Max.hu	12'/06/13