

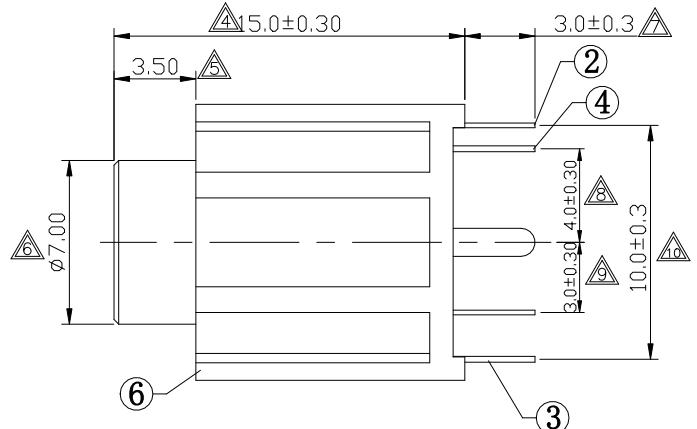

Level-I Controlled Substances are banned

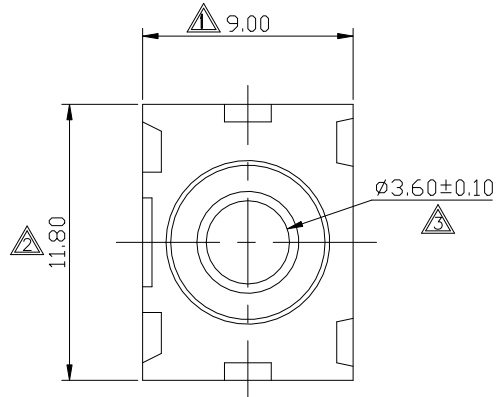

P.C.B LAYOUT  
TOP VIEW

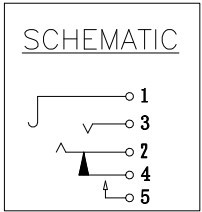
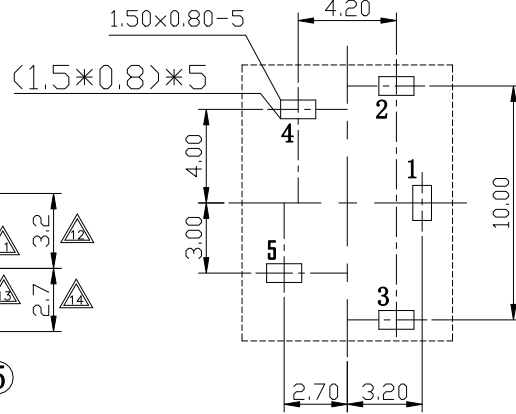

- SPECIFICATION**
1. Rating : DC 30V 0.5A;
  2. Contact resistance:  $\approx 0.03$ 次;
  3. Insulation resistance:  $\geq 100M$ 次 (DC250V);
  4. Withstand voltage: 500VAC ;
  5. Insertion and extraction force: 3-30N;
  6. life test: 5,000 cycles.
  7. Marked  $\triangle$  are important dimensions.

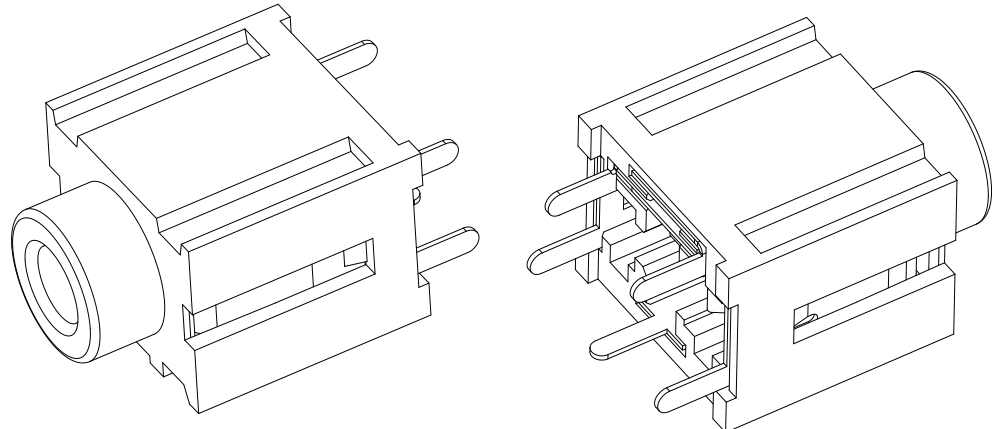
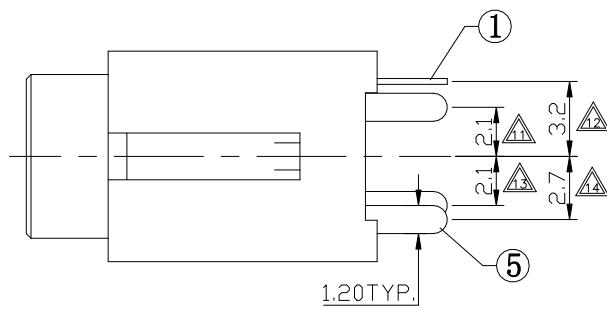

| NO. | DESCRIPTION     | QTY | MATERIAL        | COLOR | REMARK     |
|-----|-----------------|-----|-----------------|-------|------------|
| 6   | HOUSING         | 1   | PBT             | —     | —          |
| 5   | 5# CONTACT FOOT | 1   | PHOSPHOR BRONZE | —     | Ag-Plating |
| 4   | 4# CONTACT FOOT | 1   | PHOSPHOR BRONZE | —     | Ag-Plating |
| 3   | 3# CONTACT FOOT | 1   | PHOSPHOR BRONZE | —     | Ag-Plating |
| 2   | 2# CONTACT FOOT | 1   | PHOSPHOR BRONZE | —     | Ag-Plating |
| 1   | 1# CONTACT FOOT | 1   | PHOSPHOR BRONZE | —     | Ag-Plating |

| GENERAL TOLERANCE<br>UNLESS OTHERWISE SPECIFIED |             | MATERIAL                                  |            | COLOR         | REMARK                |
|---|-------------|---|------------|---------------|-----------------------|
| General   | Angle       | 盛聰电子有限公司<br>SHENG CONG ELECTRONIC CO.,LTD |            | CUSTOMER COPY | TITLE: PHONE JACK     |
| X ± 0.50  | X ° ± 3°    | PART NO.                                  |            | PJ-D3095      |                       |
| X.X ± 0.30                                      | X.X ° ± 2°  | PROJ:                                     | SCALE: 4:1 | UNIT:mm       | REV: A4 SHEET: 1 OF 1 |
| X.XX ± 0.20                                     | X.XX ° ± 1° |   |            |               |                       |
| X.XXX ± 0.10                                    |             |   |            |               |                       |

| ECN(DCN) NO. | REV | DATE      | DESCRIPTION | CHANGE | APPRO. |
|--------------|-----|-----------|-------------|--------|--------|
|              | 0   | 12'/05/07 | NEW         | JASON  | Max.hu |
|              |     |           |             |        |        |
|              |     |           |             |        |        |